

Cyber800 MKII

SAFETY INSTRUCTION

To avoid personal injury or damage to equipment, please ensure that you read this manual in its entirety before attempting to operate the equipment. Please retain this manual for future reference.

TO PREVENT THE RISK OF ELECTRIC SHOCK, DO NOT UNDER ANY CIRCUMSTANCES REMOVE ANY PARTS OF THE EQUIPMENT COVER. THERE ARE NO USER SERVICEABLE PARTS INSIDE. ALL SERVICING MUST BE CARRIED OUT BY QUALIFIED SERVICE PERSONNEL.

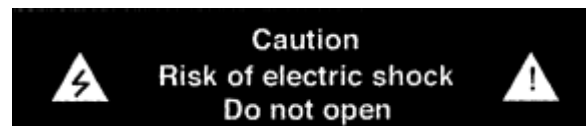

This icon marks a presence of un-insulated "dangerous voltage" within the product's enclosure that may be of sufficient magnitude to constitute a risk of electric shock to persons.



This icon marks important operating, maintenance and service information that should be read to prevent possible personal injury

WARNINGS



Do Not Disassemble

Do not attempt to service the equipment beyond that described in this manual. Touching the equipment's internal parts could result in severe personal injury. All other servicing or problems as listed below should be referred to qualified Consonance service technicians:

- The power supply cord or plug has been damaged
- Objects have fallen or liquid has been spilled into the equipment
- The equipment does not appear to function normally or exhibits a marked change in performance
- The equipment has been dropped or the enclosure damaged

Do not under any circumstances allow anyone to modify your Consonance equipment without first checking with Opera Audio, your dealer, or your distributor. Unauthorized modifications will invalidate your guarantee.



Power Source

The equipment should be connected to a power supply only of the type described in this manual or as marked on the equipment.



Grounding or Polarization

Power supply cords should be routed so that they are not likely to be walked on or pinched by items placed upon or against them, paying particular attention to cords and plugs, convenience receptacles, and the point where they exit from the amplifier.

Ventilation

The equipment should be situated so that its location or position does not interfere with its proper ventilation.

1. The equipment must not be placed on bed, sofa, or similar surfaces, that may block the ventilation openings,
2. The equipment must not be placed in a built-in installation, such as a bookcase or cabinet that may impede the flow of air.
3. The equipment should be situated away from heat sources such as radiators, heat register, stoves, or other electronic appliances that produce heat. This equipment is not intended for commercial use.

Water and Moisture

The equipment should not be used near water, e.g., near a bathtub, washbowl, kitchen sink, laundry tub, in a wet basement, or near a swimming pool etc. Similarly, do not place objects filled with liquid, such as vases on top of the equipment.

Speaker Impedance

For best performance, the load presented by the speaker has to match the Cyber-800's output impedance per channel. Refer to the speaker's manufacturer handbook for information on the nominal impedance. The Cyber-800 is factory set to match the speakers at 8 ohms and 4 ohms.

Lighting

Consonance hi-fi system can be damaged by lightning. Power amplifiers are particularly at risk and therefore should be turned off when there is risk of lightning strike. For complete protection all mains plugs and any aerial cables should be disconnected when not in use.

Power Lines

In case of connecting a tuner, an outdoor antenna should be located away from power lines. If an outside antenna is connected to the system, be sure the antenna is grounded so as to provide some protection against voltage surges and built up of static charges.

Cleaning

Never clean with furniture polish, benzene, or volatile liquids. Dust periodically with a clean, soft paint brush. Fingerprints can be removed with a moist polishing cloth.

Table of Contents

SAFETY INSTRUCTION

1.	INTRODUCTION	2
2.	UNPACKING & SET-UP	2
3	OPERATING TIPS	3
4.	GENERAL WARNINGS	4
5.	TROUBLESHOOTING GUIDE	4
6.	TECHNICAL SPECIFICATION	6
7.	WARRANTY	7

Introduction

Thank you for the purchase of the Cyber-800 high-end tube amplifiers. Opera Audio welcomes you to the growing number of discerning audiophiles who own Opera Audio products. This manual has been prepared to help you to maximize your enjoyment of the performance and features of your new Consonance equipment. Please study this manual carefully and become acquainted with all the features, operation and capabilities of your new Consonance equipment. Should you have any questions, or desire information on other Opera Audio products, please contact your local Opera dealer.

Unpacking & Set-up

Unpacking

Before any Opera Audio product leaves the factory it is carefully inspected for physical imperfections as a routine part of Opera Audio's stringent systematic quality control. After you have unpacked the equipment, carefully inspect for any physical damage. Save the shipping carton and packing materials as they are essential for future use to reduce the possibility of transportation damage.

Set-up

1. Check Equipment Voltage

Ensure that the operating voltage of the amplifier, check the shipping carton label and/or owners manual, conforms to the delivery voltage of your local power supply (i.e. 240V / 230V / 220V / 115V / 100V AC dependent on country).

2. Positioning the Equipment

The amplifier may generate considerable heat during normal operation. Please ensure that the unit is far away from effect of any domestic heat source and adequate air circulation around the unit is provided to maintain cool operation. For air circulation, leave enough space around the unit (at least 3 cm on the top and 3 cm on the sides and leave enough space on the back for the power cord and interconnect cables). If the equipment is going to be mounted in an enclosed cabinet, it is recommended that the rear of the cabinet has vents to allow air to circulate around the unit. With these considerations implemented, the equipment should then provide exceptional performance as intended. However, the usual protection of equipment from excessive dust and moisture should always be observed. All the equipment made by Opera Audio has been carefully designed with high quality components so that Long-term undiminished performance is operated in accordance with the instructions provided.

3. Install Vacuum Tubes

Locate the 6CA7, 5687 and E88CC vacuum tubes and insert them into their sockets according to the print on top lid. Pay attention on the proper tube orientation please and be sure to hold the tube by its base when inserting and removing. This will minimize the chance of breaking the glue between the socket and the glass.

4. Connect Signal Cables

Connect the input source to the amplifier's right and left channel RCA jacks. Refer to rear chassis drawing for connection location. These jacks are labeled with colored washers: red for right and black for left.

5. Connect Speaker Cables

Connect the speaker cables. Refer to rear chassis drawing for speaker connector location. Be sure the positive speaker lead is connected to the plus symbol on the speaker connector (In this case, red to red, black to black) Note: NEVER switch on the amplifier unless a speaker is connected to both output terminals. Operation of the amplifier without a load may damage the output transformers.

Operating Tips

A. Power cord, plugs and sockets

The power cord should be routed so that it is not likely to be stepped on or pinched by items placed upon or against it. All the plugs and sockets supplied with your Consonance equipment have been chosen because they mark the best possible connection for their purpose. A poor contact will degrade the signal substantially, plugs and sockets should look clean and free from corrosion. The easiest way to clean them is to switch off the equipment, pull the plugs out of their sockets, and push them back in again. Special contact cleaners and contact enhancers should not be used as they tend to deposit a film, which is very difficult to remove and may degrade the sound.

B. Switching on and off

Source components and power supplies for CD players, tuners, preamplifiers and crossovers should be switched on before switching on the amplifier(s). Always switch the amplifier(s) off and wait about 5 minute for its power supply capacitors to discharge before connecting or disconnecting any leads. Always use the power switch on the equipment instead of the mains outlet switch.

C. Running in

Your Consonance equipment will take a considerable time to run-in before it performs at its best. The duration varies, but under some conditions you will find that the sound continues to improve for as much as five weeks. Better and more consistent performance will be achieved if the system is left switched on for long periods. However, please take note that all electronic equipment can be damaged by lightning and should not be left on for long periods unattended.

D. Power supply

Where fused plugs are used various amp fuses should be fitted. Fuses of a lower rating will fail after a period of use. A hi-fi system usually shares a main circuit with other household equipment some of which can cause distortion of the mains waveform. In some Consonance equipments such distortion can lead to a mechanical hum from the transformers. The hum is not transmitted through the speakers and has no effect on the performance of the system but is purely local to the transformer. A separate fused mains circuit (like that reserved for electric cookers) will have lower impedance, supply cleaner power, and consequently improve system performance. Do not wire voltage dependent resistors or noise suppressors into mains plugs. They degrade the mains supply and the sound.

E. Positioning

Power supplies and amplifiers should be located at a reasonable distance away from other equipments in the system. Adequate spacing will prevent the generation of transformer resonance which in turns causing audible hum to be heard from the loudspeakers. The minimum recommended distance is 300mm (12 inches), and that allowed by the standard interconnect lead being maximum.

Many of the Consonance equipments, due to stringent requirements for ultimate sonic reproduction, are extremely heavy in weight. If you are placing the equipments on equipment rack or table please ensure that the frame is structural sound for supporting the total weight of the equipments.

F. Cables, connections and speaker Impedance

Loudspeaker leads are also very important leads to suit your equipment installation. The leads should each be at least 3.5 meters long and of equal length. The recommended maximum is 20 meters. The loudspeaker connectors supplied with all Consonance amplifiers and loudspeakers have been specifically designed to make a tight mechanical connection. It is essential that these are used in order to comply with local safety regulations.

For best performance, the load presented by the speaker has to match the amplifier's output impedance. Refer to the manufacturer's information for your speaker nominal impedance. All vacuum tube amplifier made by Opera Audio are factory set to match the speakers at 8 ohms and 4 ohms.

General Warnings

Every piece of Consonance equipment is designed to produce the finest sound quality that can be achieved, by avoiding compromise wherever possible. This can lead to circumstances that may be unfamiliar to the equipment owner. The material that follows contains advice specifically related to Consonance equipment as well as more general warning about the use of domestic audio products.

Please read it carefully:

The transformers in Consonance amplifiers and power supplies may sometimes make a mechanical noise caused by distortion of the mains waveform. Consonance transformers are large in size and have heavy gauge secondary windings making them relatively sensitive to such distortion. A separate mains circuit for your hi-fi system may reduce the effect while also giving an overall improvement in sound quality. It may be necessary however to take account of mechanical transformer noise when placing your equipment.

In some circumstances, depending on where you live and the grounding arrangements in your home, you may experience radio frequency interference. Controls on broadcasting in some territories allow very high levels of radio frequency radiation and both the choice and exact placement of equipment may be critical. If there is a known problem in your locality it is advisable to arrange for a home demonstration before purchase to ensure that your selected Consonance equipment can be operated normally. Susceptibility to radio frequency interference is related to the wide internal bandwidth necessary for high sound quality. Systems incorporating moving coil phono preamplifiers and active crossovers are more likely to suffer.

Troubleshooting Guide

From time to time you may experience problems in obtaining optimum equipment performance. Following is list of frequently encountered problems.

Problem	Solution
Power indicator and filaments do not light	Check the fuse and make sure the amplifier is plugged into a working power outlet
Sound out of one speaker only	Turn volume control fully counter-clockwise and reverse input connectors. If sound changes from one speaker to the other, check source or replace inter-connect wires. If the sound is still coming out of the same speaker only, check speakers on another piece of equipment for proper operation.
Static, noise, or hum	Turn the potentiometers Individually clockwise or counter-clockwise until the hum reduces to the lowest level on each channel

Equipment problem could also be caused by fault in any part of the system or its installation. As Legal consumer protection varies from country to country, you should always first consult the local dealer for any technical problems that you may experience. Please contact your local distributor or Opera Audio at the address in the back of this manual for any difficulties that cannot be resolved.

Certain Consonance equipment is made in special versions for different territories as a result it is impracticable to arrange international guarantees. Please establish appropriate guarantee arrangements with your own dealer at the time of sale. We are always available to offer help and advice. It is essential that repairs and updates are only carried out by authorized Consonance dealer or Opera Audio factory. As many Consonance components are custom made and specially matched, the replacement parts must be ordered through Opera Audio or its representative. Our dealer will have all relevant information about the service in your area and will ensure that you equipment is serviced without delay.

If for some reason, there are no service facilities available in your area, please ship the equipment to the address listed at the back of the manual.

Please note that you are responsible for all shipping charges, insurance, and re-importation to your country, and duty arrangements.

When shipping a product back to factory for service, always include the following:

- Sales slip or other proof of purchase if repair is claimed under warranty.
- A proforma invoice with value of the goods, stating that the amplifier is returned to china for repair.
- An accompanying letter describing faults, symptoms or problems with the amplifier.
- Always ship the amplifier in its original carton and packaging material to prevent damage in transit.

Opera Audio will not accept responsibility for any damage caused in transit, no matter whatever caused.

6. Technical Specification

- ① Power indicator
- ② Power switch
- ③ Input jacks (RCA red / white)
- ④ Speaker output
- ⑤ Power plug
- ⑥ S/N

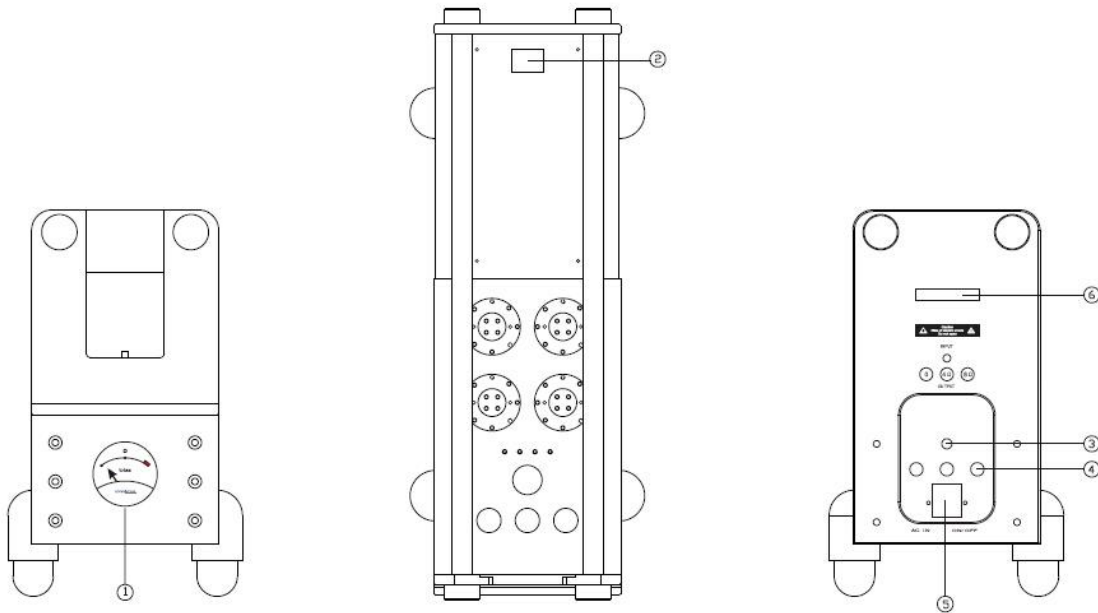

TECHNICAL SPECIFICATION

CONTROL FUNCTIONS: **Power On/Off**

POWER OUTPUT: **100 watt x 2, RMS 1kHz (Ultra-linear)**

TOTAL HARMONIC DISTORTION: **less than 1%(50watt, 1kHz)**

FREQUENCY RESPONSE: **(-3dB points at 50 watt) 6Hz-52kHz**

INPUT SENSITIVITY: **980mV**

INPUT IMPEDANCE: **100k ohms**

OUTPUT IMPEDANCE: **4, 8 ohms. (User selectable)**

SIGNAL/NOISE: **90dB**

CONSUMPTION: **180watt x 2**

INPUT INTERFACES: **1 group (RCA)**

OVERALL NEGATIVE FEEDBACK: **Little**

VACUUM TUBE: **KT88 x 8, 5687x 2, 12AU7 x4**

DIMENSIONS: **565 (L) x185 (W) x380(H)mm x 2**

WEIGHT: **25kg x 2**

SPECIFICATIONS SUBJECT TO CHANGE WITHOUT NOTICE.

7.Warranty

Opera audio guarantees each product manufactured by us to be free from defects in materials and workmanship under normal use. Our obligation under this warranty is limited to making good at our factory any part or parts thereof which shall, within 1 year after delivery to the original purchaser, be returned to us with transportation charges prepaid, and which an examination shall disclose to have been thus defective; this warranty being expressly in lieu of all other warranties expressed or implied and of all other obligations or liabilities on our part. This warranty shall not apply to any Opera audio product which shall have been repaired or altered outside of our factory in any way so as to affect its stability, nor which has been subject to misuse, negligence or accident. Warranties of the vacuum tubes are by the respective manufacturers, usually 90 days.

Please mail or e-mail the Registration Card to the address as follows:

The Opera Audio Co., Ltd.

No.2 JiuXianQiaoLu
ChaoYang District
Beijing, China
Tel: 86 10 59789215
Fax: 86 10 59789265
support@opera-consonance.com
www.opera-consonance.com



Registration Card

Name
Address
City
State
Zip
Email
Telephone
Model
Serial Number
Purchase Date
Dealer