

LIU Turntable

USER GUIDE

Congratulations on your new CONSONANCE!

Opera Audio products are based on a simple philosophy:

The component shall reproduce the original musical sound, purely and naturally.

The products are easy to operate and are manufactured according to the best quality principles.

All CONSONANCE products are created with acoustical instruments in a concert situation as point of reference. The music is reproduced exactly like the original and is limited only by the quality of the recording.

Our aim is to give you the best possible music experience!

CONTENTS

Partlist	p.1
Assembling the Turntable	p.2
Technical specifications	p.5
Use & Placement	p.5
Cleaning	p.5
Note & Warning	p.5
WARRANTY	p.6

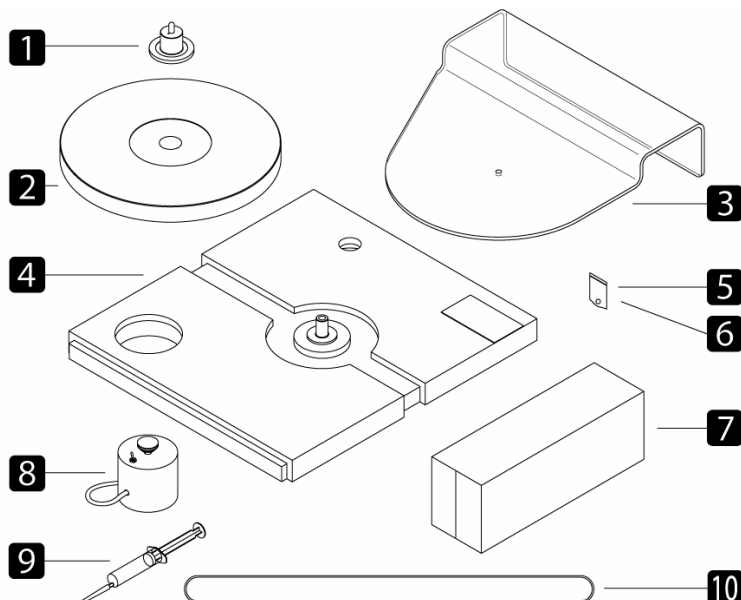

Partlist

- 1.bearing housing
- 2.platter
- 3.dust cover
4. turntable base
5. ball for bearing (ceramic)
7. T988 tone-arm
- 8.motor
9. lubrication oil
10. belt

Assembling the Turntable

1. Open the box and take out the main turntable base. Remove the protective covering of the bearing shaft and ensure it is totally clean using a lint free cloth.

2. Using the supplied syringe put a few drops of oil into the hollow at the top of the bearing shaft, and if needed, dropping the oil slide down onto the internal surface of bearing housing. Place the ball bearing into this hollow and put one drop of oil on its top. Gently rotate the ball using your finger to ensure it is covered with a thin film of oil.

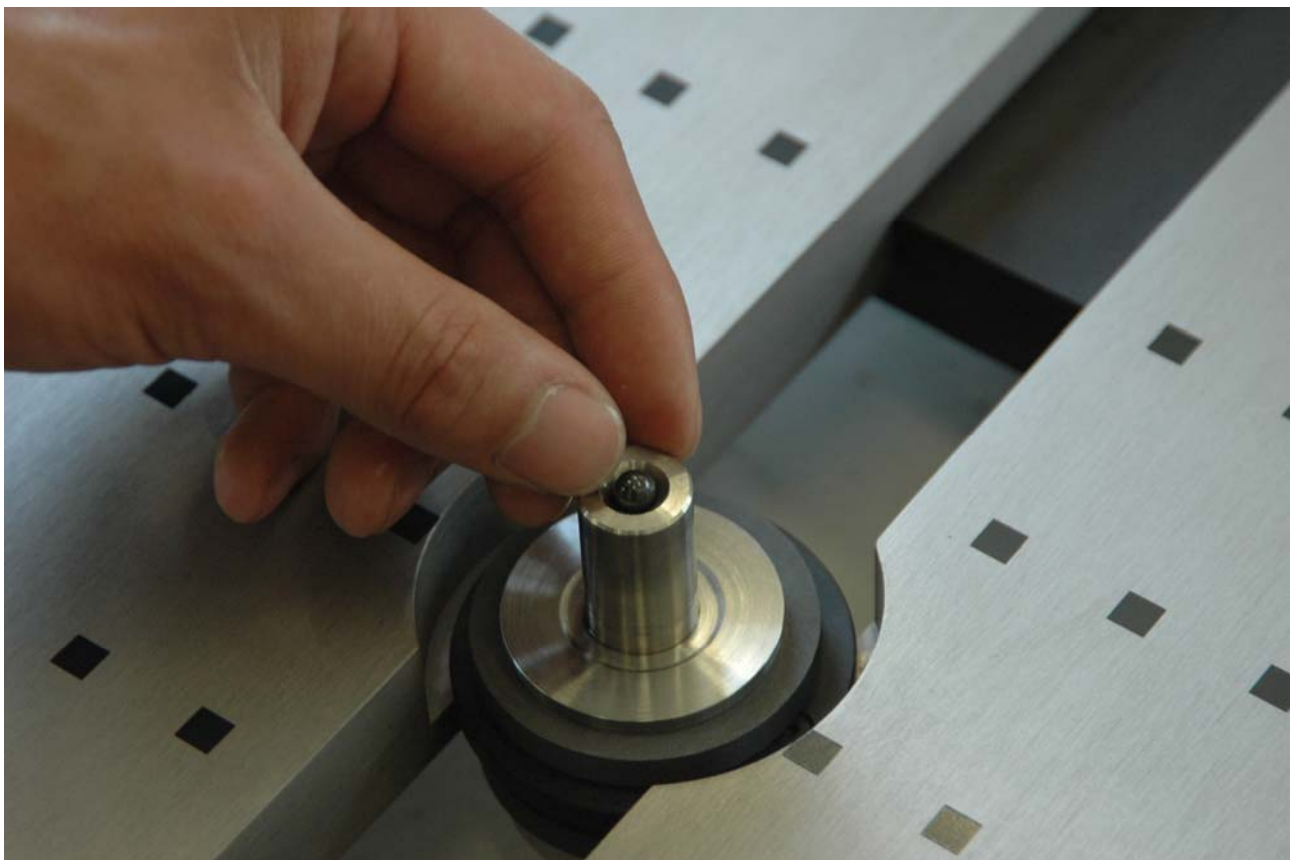

3. Put the bearing housing very gently down over the shaft taking care not to displace the ball. It will be a very tight fit but once engaged it can drop suddenly - lower the bearing housing carefully by hand to prevent this. Now spin the bearing to ensure it runs smoothly.

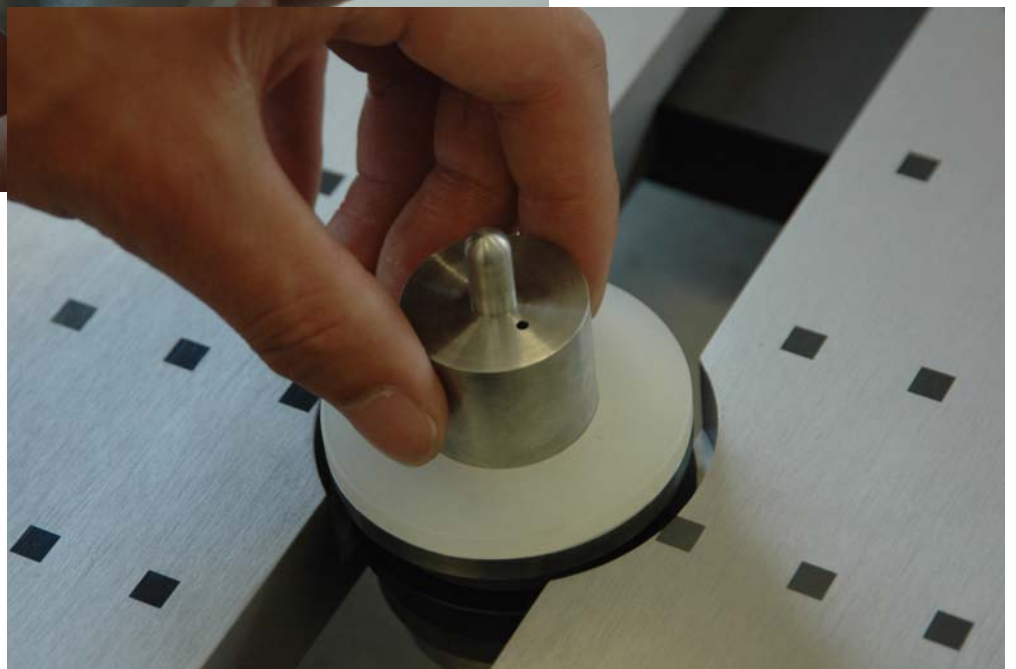

5. If it's not smooth enough, use the syringe to fill the small hole at the top of the spindle. Once you've done this turn the bearing whilst gently lifting the bearing housing. The oil will disappear into the bearing and wash down the shaft. Because of the very tight clearances of the bearing there may still be small amounts of 'friction' - this will disappear as the bearing runs in.

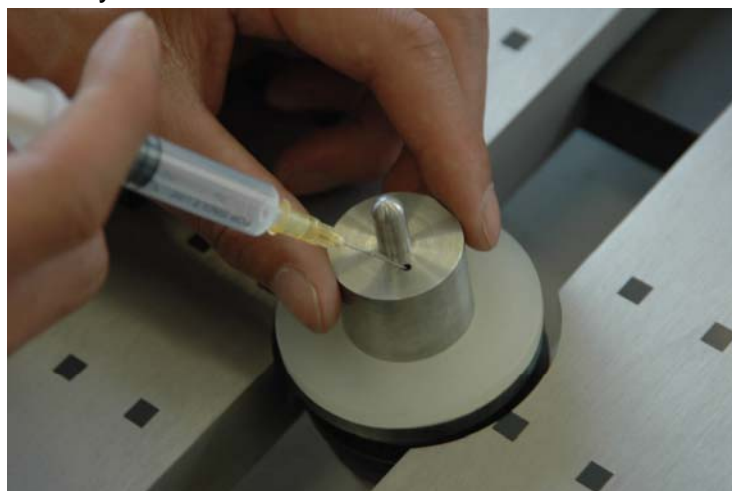

6. Put on the cotton gloves and pick up the acrylic platter, with the dip for the record label uppermost. Hold it level over the bearing housing, locate it carefully and gently lower it until it seats fully over the bearing.

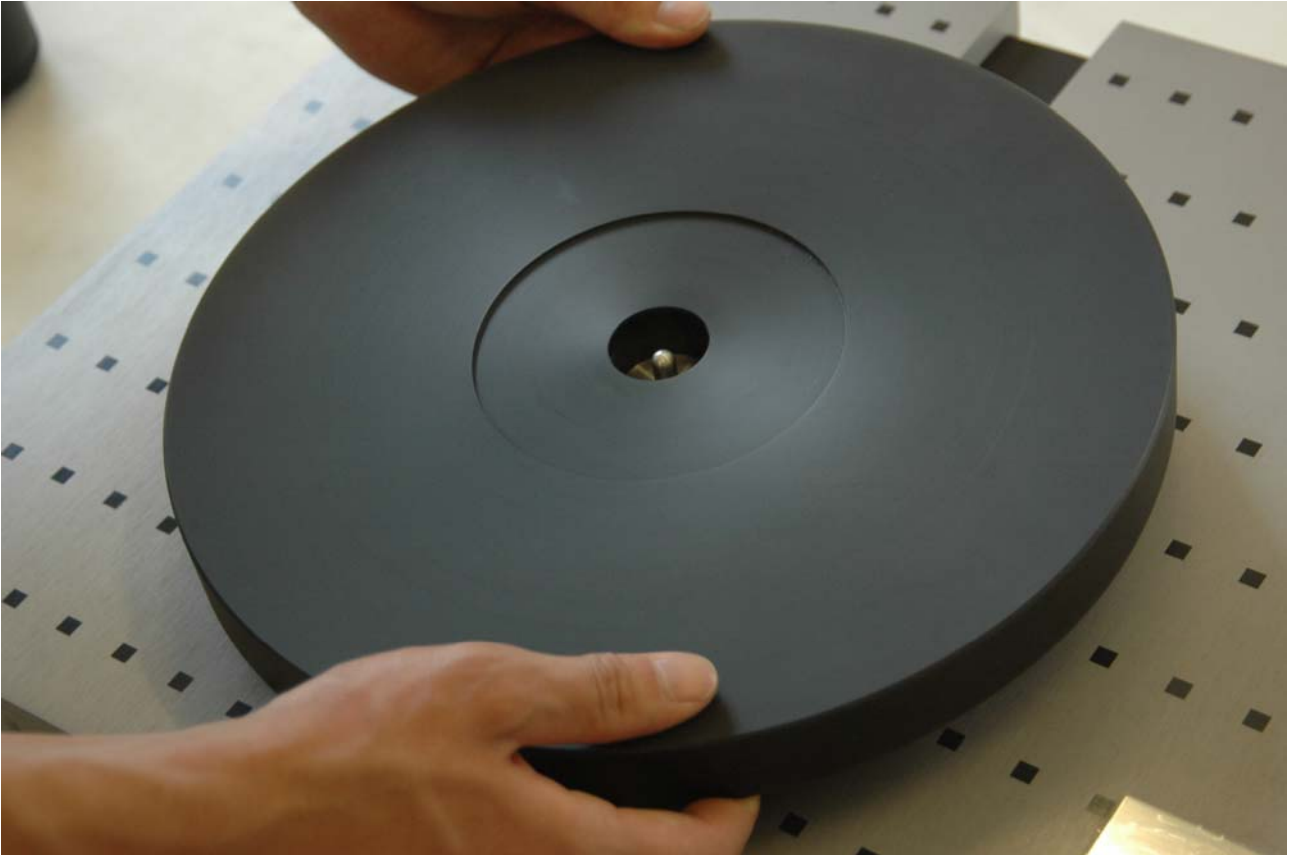

7. Take out one of the drive 'belts' and run it round the motor spindle and then round the platter. There are two ruts on the pulley of motor. The above rut is for 45 rpm, and the nether rut is for 33.3 rpm. Different ruts for the different speed. Only one switch control the motor. It could be found on the top of the motor housing and is a simple on/off.

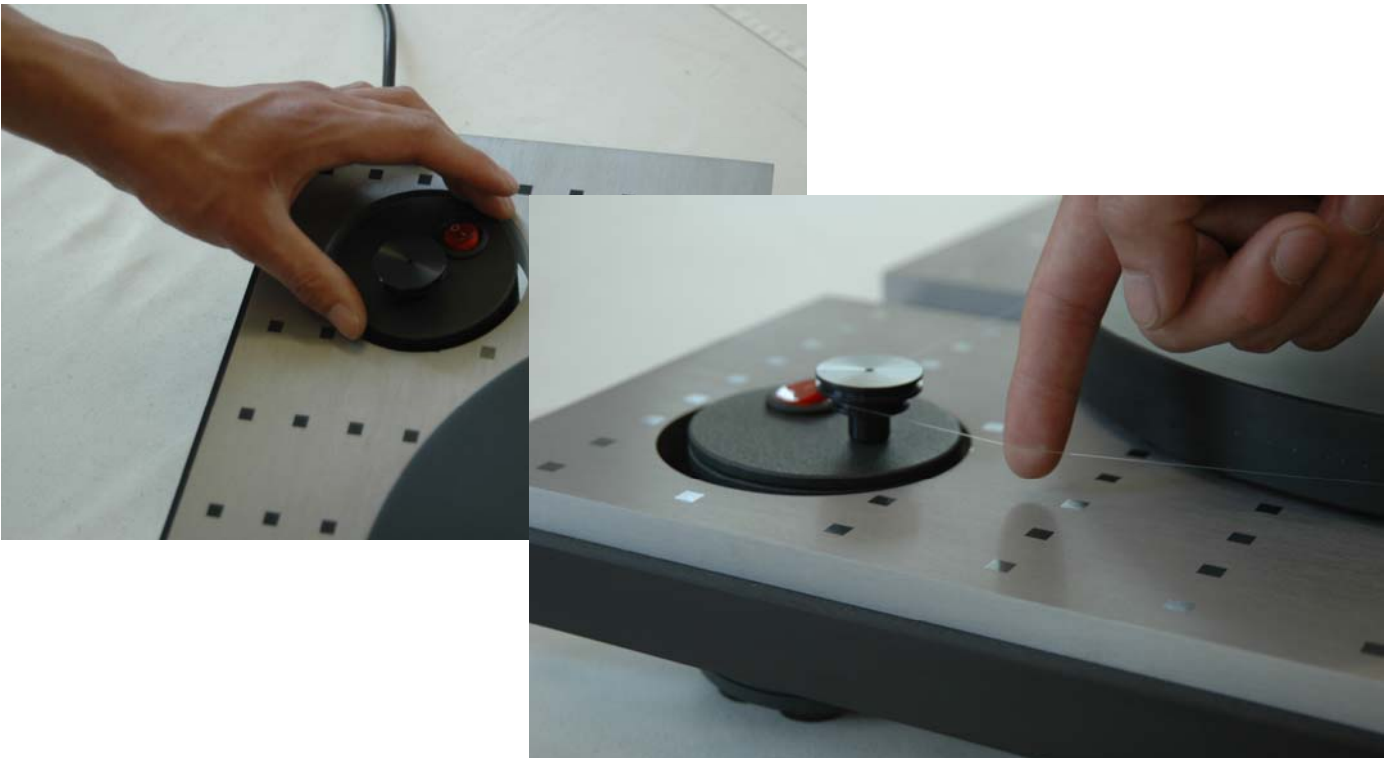

last step: Use the adjustable feet of the turntable to level the turntable using the extra spirit level.

TECHNICAL SPECIFICATION

Wow and Flutter: Less than 0.02

Rumble: Greater than 80dB down

Speed accuracy: Within 0.01%

Motor AC power :

100V~240V 50Hz / 60Hz AC dependent on country.



USE & PLACEMENT

The Consonance LIU should be placed on a flat, hard surface for proper standing. The turntable performs best after being switched on for 5 minutes for running smooth. A certain space is required for tonearm moving above the turntable on the right side. The turntable must never be placed on a soft or unstable base. Nor must it be covered while in use or placed on a narrow shelf or in another confined space.

CLEANING

The base of the turntable and turnarm as well as the motor are made of solid, powder coated aluminum. Fingerprints can be removed with a cloth moistened with warm water. A silk cover would be the best keeping dust away from the whole LP system.

NOTE & WARNING

Opening of the product by non-authorized personnel will void the guarantee.

The products must not be exposed to rain or moisture.

Motor should only be opened or serviced by certified technicians. The devices contain electronic components that can cause severe electric shock. Work performed on Consonance products by unqualified personnel can cause serious damage and personal injury.

WARRANTY

Opera audio guarantees each product manufactured by us to be free from defects in materials and workmanship under normal use. Our obligation under this warranty is limited to making good at our factory any part or parts thereof which shall, within 1 year after delivery to the original purchaser, be returned to us with transportation charges prepaid, and which an examination shall disclose to have been thus defective; this warranty being expressly in lieu of all other warranties expressed or implied and of all other obligations or liabilities on our part. This warranty shall not apply to any Opera audio product which shall have been repaired or altered outside of our factory in any way so as to affect its stability, nor which has been subject to misuse, negligence or accident. Warranties of the vacuum tubes are by the respective manufacturers, usually 90 days.

Please mail or e-mail the Registration Card to the address as follows:

The Opera Audio Co., Ltd.

No.2 JiuXianQiaoLu

ChaoYang District

Beijing, China

Tel: 86 10 59789461

Fax: 86 10 59789265

support@opera-consonance.com

www.opera-consonance.com



Registration Card

Name

Address

City

State

Zip

Email

Telephone

Model

Serial

Number

Purchase

Date

Dealer